

Performance curves 50Hz

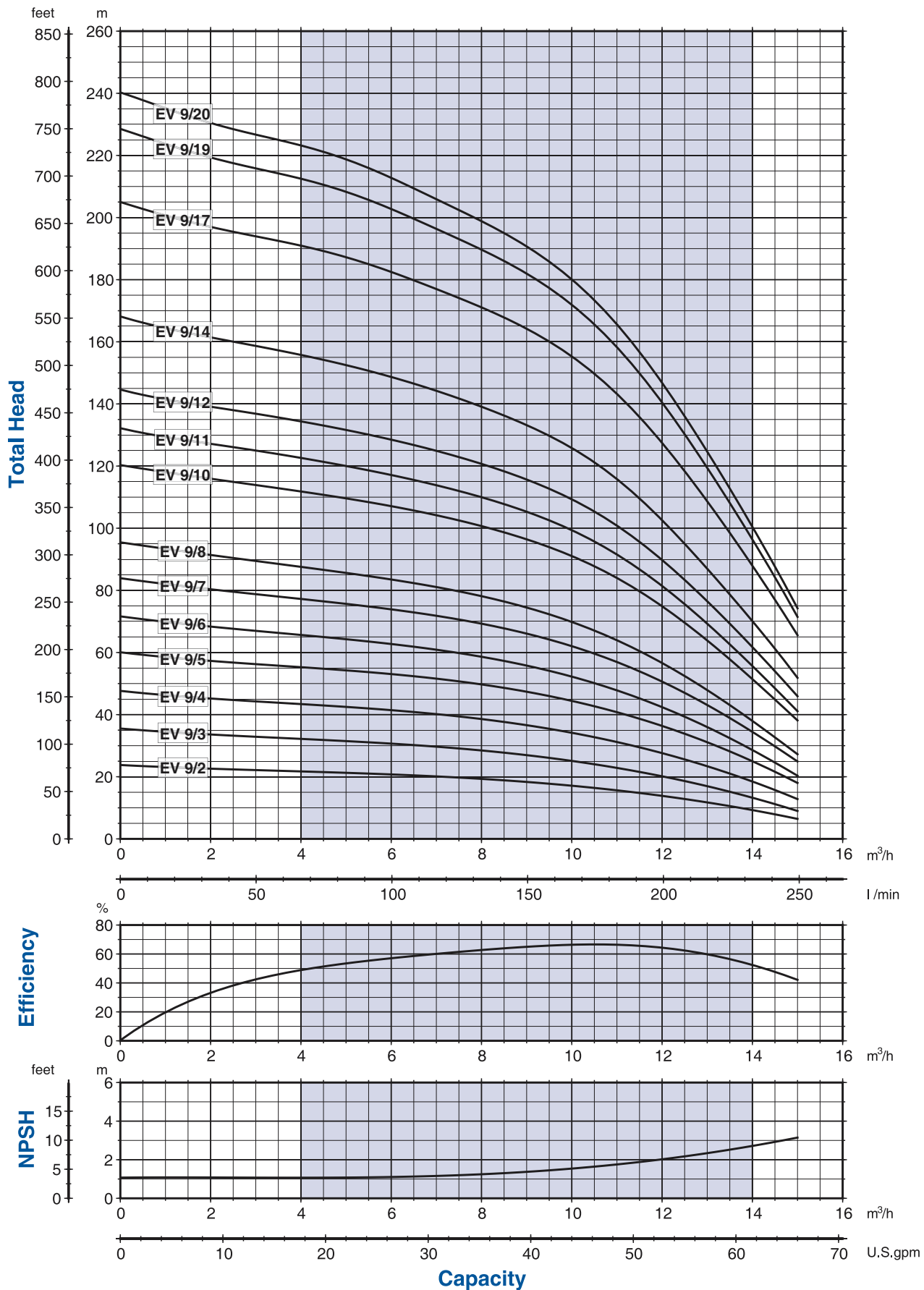

00110041 07/2008

The hydraulic characteristics are guaranteed, according to ISO standard 9906, Annex A, grade 2.



It is our policy to continuously develop and improve our products, therefore, we reserve the right to amend specifications without prior notice.

by Franklin Electric

F version

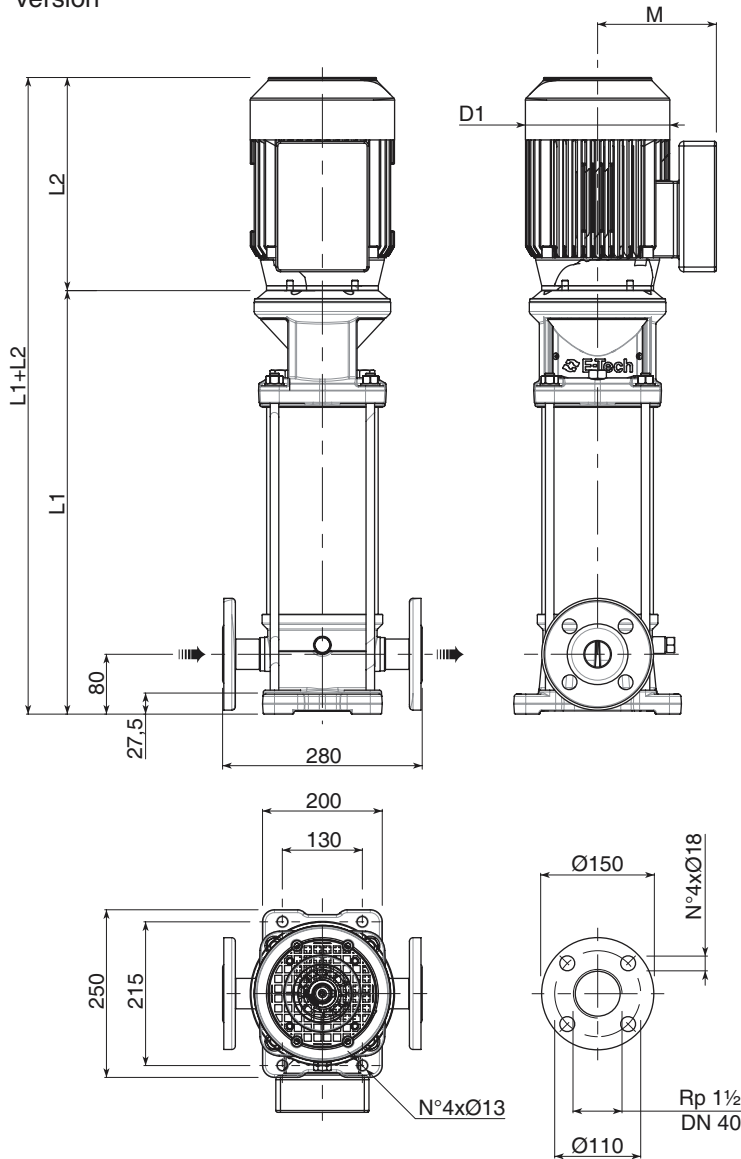

T version

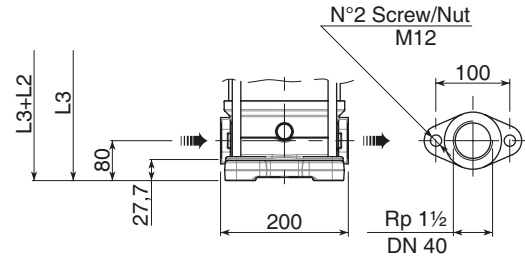

V version

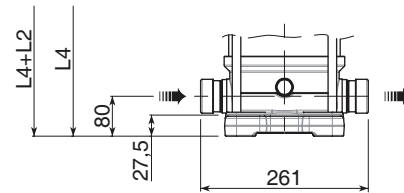

C version

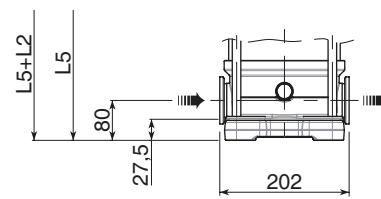

00114014_05/2009

F version Round flanges on body type PN25: the pump is supplied with joints and bolts without counterflanges (Optional accessories).

V version Connections with rapid fittings type "Victaulic": the pump is supplied without the collars (Optional accessories).

T version Oval flanges on body type PN16: the pump is supplied without oval counter flanges for pipe to be screwed, joints and bolts (Optional accessories).

C version Connections with round fittings type Clamp-FlexiClamp: the pump is supplied without collars (Optional accessories).

Pump Model	Motor		Dimensions (mm)									Weight		
	kW	Size	L1 F	L2		L3 T	L4 V	L5 C	M		D1		Pump	Electric Pump
				1-PHASE	3-PHASE				1-PHASE	3-PHASE	1-PHASE	3-PHASE		
EV 9/2	0.75	80	347.5	232	232	347.5	347.5	347.5	150	129	160	160	17.5	27
EV 9/3	1.1	80	377.5	232	232	377.5	377.5	377.5	150	129	160	160	18	29.5
EV 9/4	1.5	90	417.5	267	267	417.5	417.5	417.5	160	138	180	180	19	33
EV 9/5	2.2	90	448	267	267	448	448	448	160	138	180	180	20	36
EV 9/6	2.2	90	478	267	267	478	478	478	160	138	180	180	21	37
EV 9/7	3	100	518	-	306	518	518	518	-	145	-	196	22	45
EV 9/8	3	100	548	-	306	548	548	548	-	145	-	196	23	34
EV 9/10	4	112	608	-	328	608	608	608	-	161	-	225	24.5	58
EV 9/11	4	112	638	-	328	638	638	638	-	161	-	225	25	58.5
EV 9/12	5.5	132	690.5	-	362	690.5	690.5	690.5	-	195	-	248	30.5	76.5
EV 9/14	5.5	132	750.5	-	362	-	750.5	750.5	-	195	-	248	32	78
EV 9/17	7.5	132	840.5	-	362	-	840.5	840.5	-	195	-	248	34.5	87.5
EV 9/19	7.5	132	900.5	-	362	-	900.5	900.5	-	195	-	248	36	89
EV 9/20	7.5	132	930.5	-	362	-	930.5	930.5	-	195	-	248	36.5	89.5