

Performance curves 50Hz

MEI ≥ 0,60

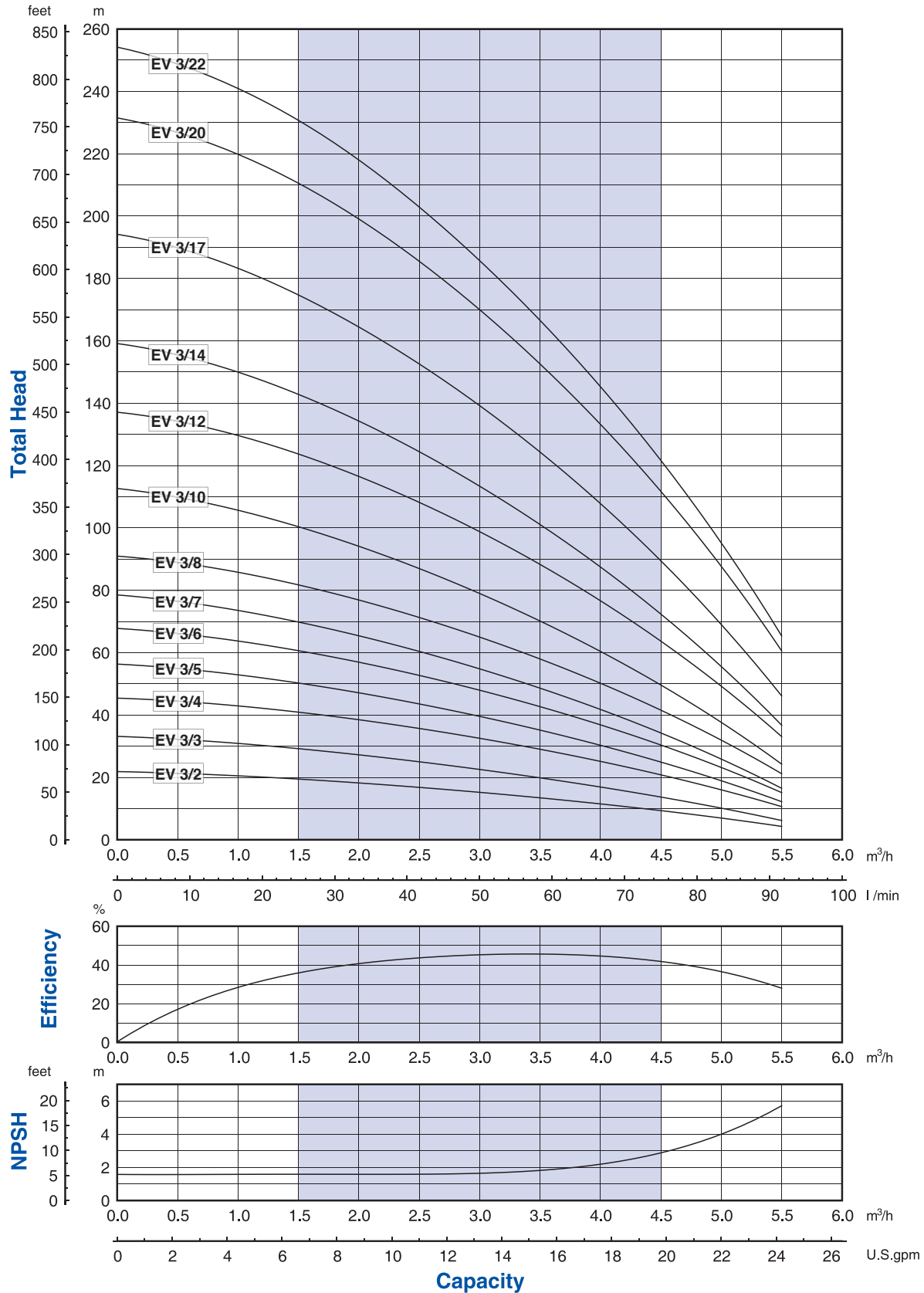

00110039 11/2013

The hydraulic characteristics are guaranteed, according to ISO standard 9906, grade 3.

It is our policy to continuously develop and improve our products, therefore, we reserve the right to amend specifications without prior notice.



Technical data 50Hz

F version

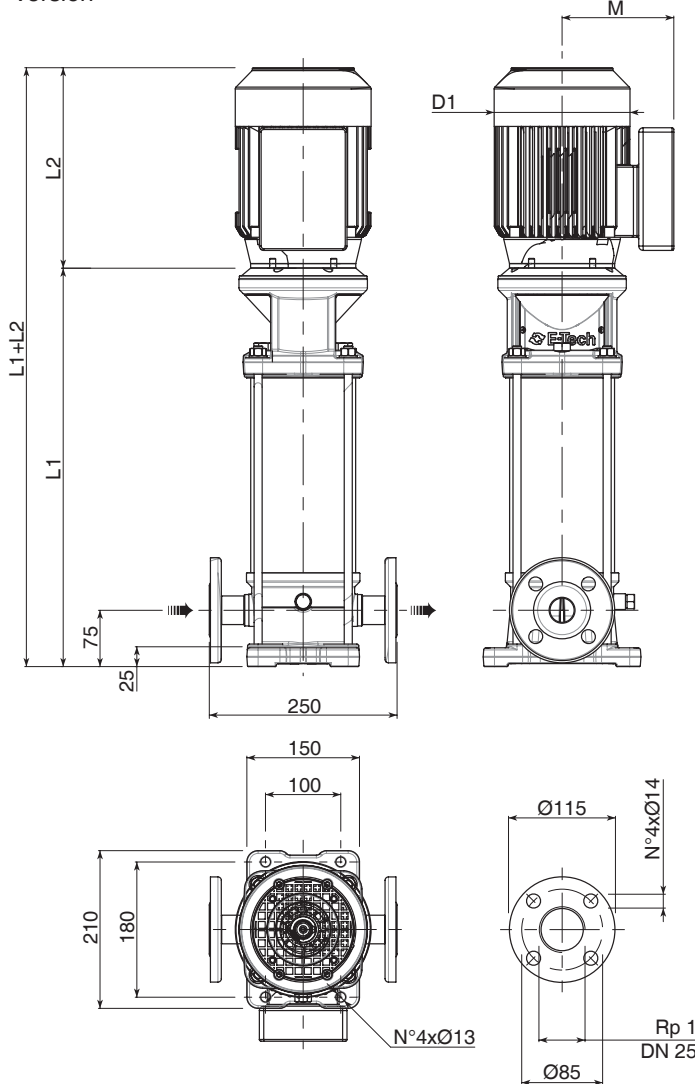

T version

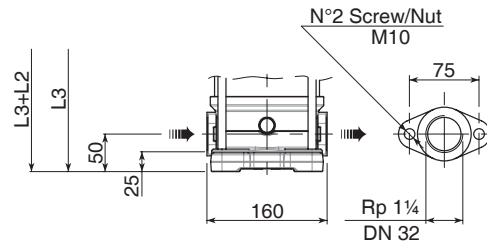

V version

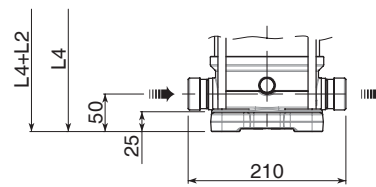

C version

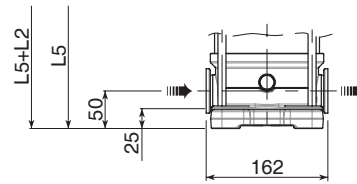

F version Round flanges on body type PN25: the pump is supplied without counterflanges (Optional accessories, including bolts and joints).

T version Oval flanges on body type PN16: the pump is supplied without threaded oval counter flanges (Optional accessories, including bolts and joints).

V version Connections with rapid fittings type "Victaulic": the pump is supplied without the collars (Optional accessories).

C version Connections with round fittings type Clamp-FlexiClamp: the pump is supplied without collars (Optional accessories).

00114014 01/2012

Pump Model	Motor		Dimensions (mm)							Weight				
	kW	Size	L1 F	L2 1-PHASE	L2 3-PHASE	L3 T	L4 V	L5 C	M 1-PHASE	M 3-PHASE	D1 1-PHASE	D1 3-PHASE	Pump	Electric Pump
EV 3/2	0.37	71	328.5	215	215	303.5	303.5	303.5	129	112	142	142	15	21
EV 3/3	0.55	71	352.5	215	215	327.5	327.5	327.5	129	112	142	142	15.5	21.5
EV 3/4	0.75	80	376.5	232	232	351.5	351.5	351.5	150	129	160	160	16	25.5
EV 3/5	0.75	80	400.5	232	232	375.5	375.5	375.5	150	129	160	160	17	26.5
EV 3/6	1.1	80	425	232	232	400	400	400	150	129	160	160	17.5	29
EV 3/7	1.1	80	449	232	232	424	424	424	150	129	160	160	18	29.5
EV 3/8	1.5	90	483	267	267	458	458	458	160	138	180	180	19	33
EV 3/10	1.5	90	531	267	267	506	506	506	160	138	180	180	20.5	34.5
EV 3/12	2.2	90	579	267	267	554	554	554	160	138	180	180	21.5	37.5
EV 3/14	2.2	90	627	267	267	602	602	602	160	138	180	180	23	39
EV 3/17	3	100	709	-	267	-	684	684	-	138	-	180	25	44
EV 3/20	4	112	781	-	306	-	756	756	-	145	-	196	27	50
EV 3/22	4	112	829	-	306	-	804	804	-	145	-	196	28.5	51.5

• Standard efficiency motors IE1

EV 3-5-9

TABLE OF HYDRAULIC PERFORMANCES AT 50Hz

PUMP TYPE	RATED POWER		Q = DELIVERY																								
	kW	HP	l/min	25	33	42	50	58	67	75	83	90	100	117	133	150	167	183	233	300	333	367	417	433,5	466,5		
			m ³ /h	0	1.5	2	2.5	3	3.5	4	4.5	5	5.4	6	7	8	9	10	11	14	18	20	22	25	26	28	
H = TOTAL HEAD METERS COLUMN OF WATER																											
EV 3/2	0.3	0.4	22	19.5	18.5	17	15	13.5	11.5	9.5																	
EV 3/3	0.55	0.75	33.5	29	27.5	25	22.5	20	17	13.5																	
EV 3/4	0.75	1	45.5	41	38.5	35.5	32.5	29	25	21																	
EV 3/5	0.75	1	56.5	50	47	43.5	39.5	35	30.5	25																	
EV 3/6	1.1	1.5	68	60.5	57	53	48	42.5	37	30.5																	
EV 3/7	1.1	1.5	78.5	70	65.5	60.5	55	48.5	42	34.5																	
EV 3/8	1.5	2	91	81.5	77	71.5	65	58	50	41.5																	
EV 3/10	1.5	2	112.5	100.5	94.5	87	79	70	60.5	49.5																	
EV 3/12	2.2	3	137	123.5	117	108.5	98.5	88.5	76.5	63.5																	
EV 3/14	2.2	3	159.5	143	134.5	124.5	113.5	101	87.5	72.5																	
EV 3/17	3	4	194.5	174.5	165	152.5	139	124.5	107.5	89.5																	
EV 3/20	4	5.5	231.5	210.5	199.5	185.5	170	152.5	133	111.5																	
EV 3/22	4	5.5	254	230.5	218.5	203	185.5	166.5	145.5	121.5																	
EV 5/2	0.55	0.75	22		21	20	19.5	18.5	18	17	16	15.5	14	11													
EV 5/3	0.75	1	34		32	31	30	29.5	28	27	26	24.5	22.5	18													
EV 5/4	1.1	1.5	45.5		42.5	41.5	40	39	37.5	36	34	32.5	30	24													
EV 5/5	1.1	1.5	56.5		52	50.5	49	47.5	46	44	41.5	39.5	36	29													
EV 5/6	1.5	2	68.5		63.5	62	60.5	58.5	56.5	54	51.5	49	45	36.5													
EV 5/7	1.5	2	79.5		73.5	71.5	69.5	67.5	64.5	62	59	56	51	41													
EV 5/8	2.2	3	92		86	84	82	79.5	77	74	70.5	67	62	50.5													
EV 5/10	2.2	3	114		106.5	103.5	101	98	94	90.5	86	82	75	61													
EV 5/12	3	4	137.5		128.5	125.5	122	118.5	114.5	109.5	104.5	99.5	91.5	74.5													
EV 5/14	3	4	159.5		148.5	144.5	140.5	136.5	131.5	126	120	114	104.5	84.5													
EV 5/17	4	5.5	196.5		184.5	180.5	176	171	165	159	151.5	145	133.5	109.5													
EV 5/19	5.5	7.5	220		206.5	202	197	192	185.5	178.5	170	162.5	150	123.5													
EV 5/22	5.5	7.5	254		237.5	232.5	226.5	220	212.5	204.5	195	186	171.5	140.5													
EV 9/2	0.75	1	23.5						22	21.5	21.5	21	20.5	20	19	18.5	17	15.5	9								
EV 9/3	1.1	1.5	35.5						32.5	32	31.5	31	30.5	29.5	28.5	27	25.5	23	13								
EV 9/4	1.5	2	47.5						43.5	43	42.5	42	41.5	40	38.5	36.5	34.5	31.5	18.5								
EV 9/5	2.2	3	60						55.5	55	54.5	54	53	51	49.5	47.5	44.5	41	25								
EV 9/6	2.2	3	71.5						66	65.5	64.5	64	62.5	60.5	58.5	56	52.5	48	28.5								
EV 9/7	3	4	84						77.5	77	76	75.5	74	71.5	69	66	62.5	57	34.5								
EV 9/8	3	4	95.5						88	87.5	86.5	85.5	83.5	80.5	77.5	74.5	70	64	38								
EV 9/10	4	5.5	120.5						112.5	111.5	110.5	109.5	107.5	104	100.5	96.5	91	84	51.5								
EV 9/11	4	5.5	132						123	122	121	119.5	117.5	113.5	109.5	105.5	99.5	91.5	56								
EV 9/12	5.5	7.5	144.5						135	134	132.5	131	129	124.5	120.5	116	109.5	100.5	62								
EV 9/14	5.5	7.5	168						156	155	153.5	151.5	149	144	139	133.5	126	115.5	70								
EV 9/17	7.5	10	205						191	190	188	186	182.5	177	170.5	164.5	155.5	143	88								
EV 9/19	7.5	10	228.5						212.5	211	209	206.5	203	196.5	189.5	182	172	158	96.5								
EV 9/20	7.5	10	240.5						223.5	221.5	219	217	213	206	198.5	191	180	165.5	100.5								